

Gothic arch break-down chairs

Original chairs by Sir Kragon, original plans by Master Terafan and now modified by Barún Pól Ó Briain

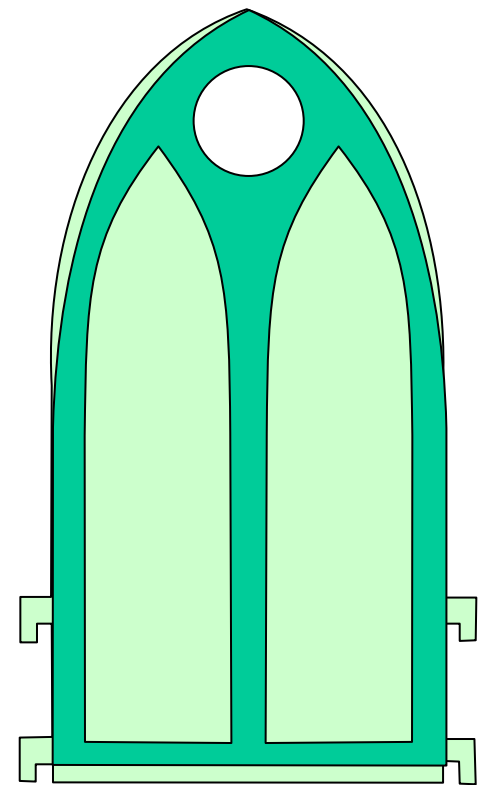

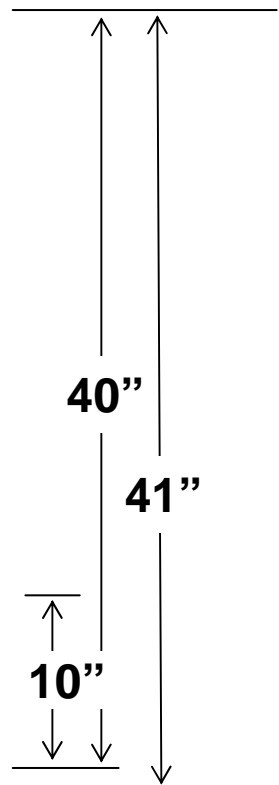
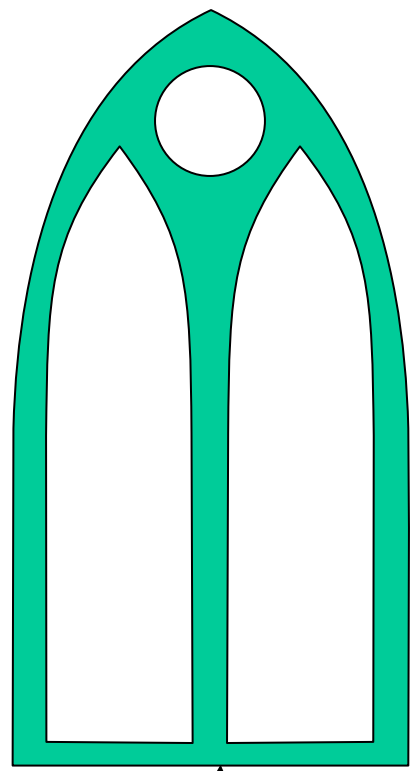
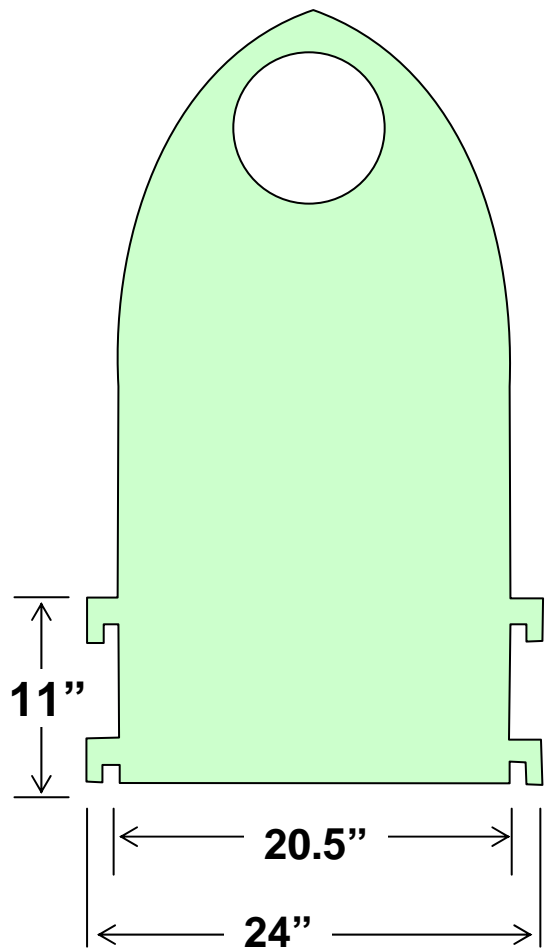

1 of each of these,
glued together

to make this chair back

Arm Rise

(Cut/assemble two per chair)

Three times the thickness of the sides

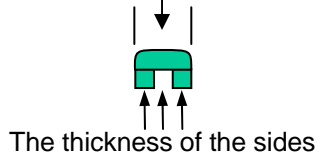

Chair Legs

(Cut two per chair)

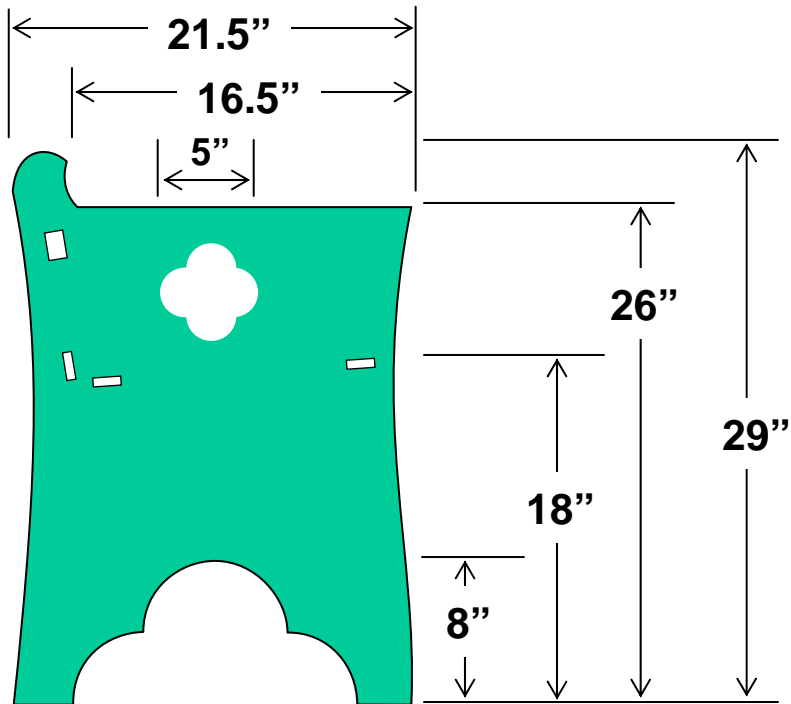

Seat

(Cut one per chair)

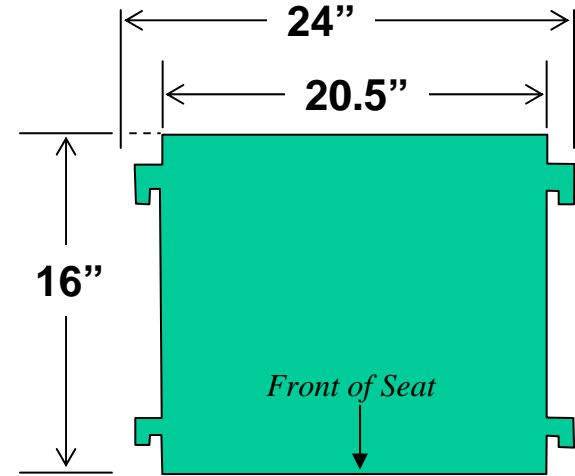

Detail of the tabs

The left space (shaded area) is the **thickness** of the sides of the chairs.
(I used $\frac{3}{4}$ " plywood.)

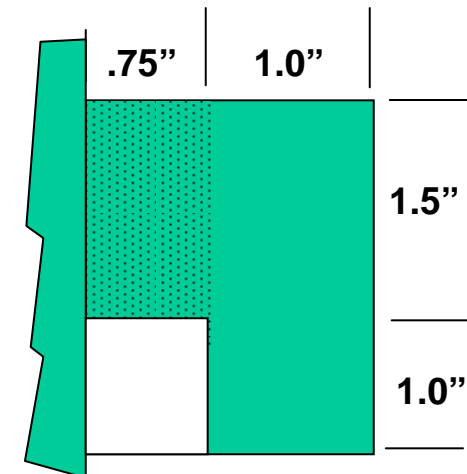

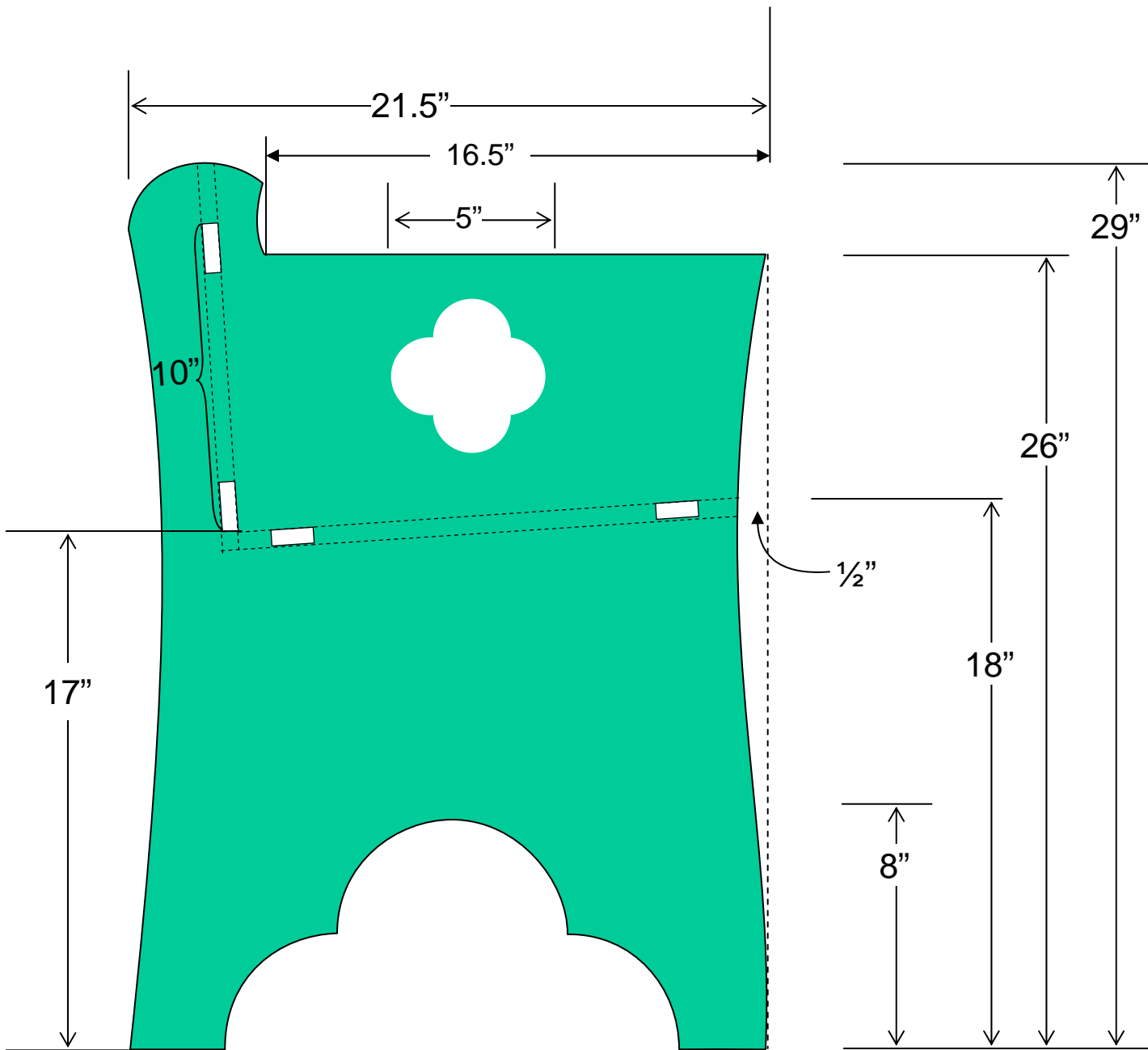

Position the seat slots so the rear of the seat is 1" lower than the front.

Make the line of the slots for the back perpendicular to the seat, (dashed line)

How to layout on 4' X 8' sheets of Plywood

12mm or 1/2" Plywood

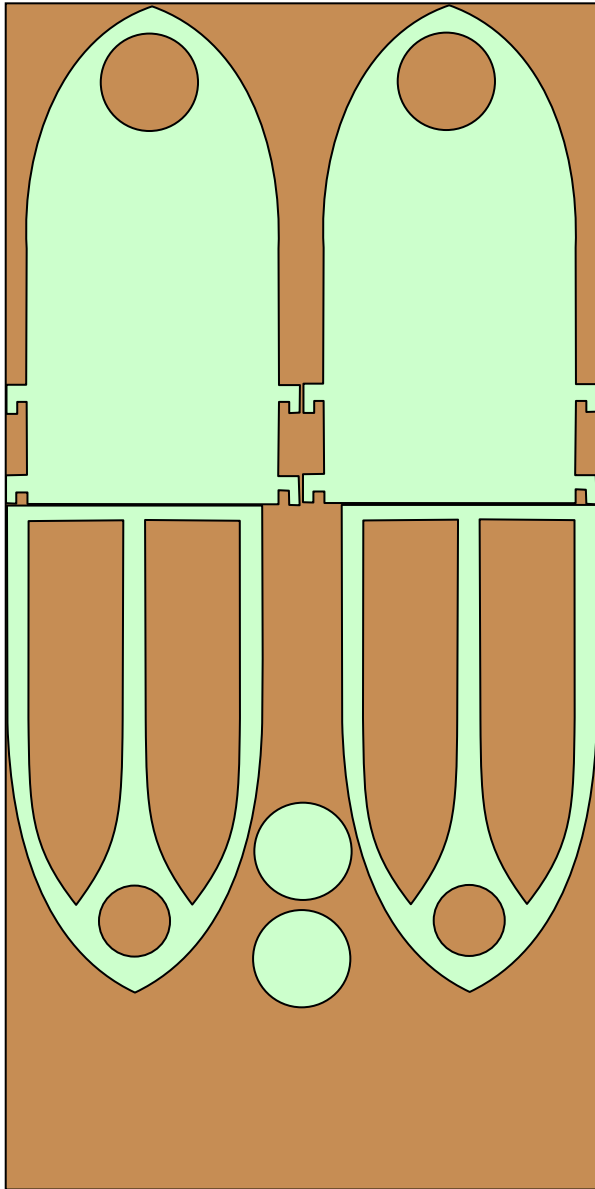

18mm or 3/4" Plywood

